

CURVED UNIT WORKTOP

FITTED FURNITURE INSTALLATION GUIDE

This guide is to be used in conjunction with the Curved Base End Worktop Jig (7035.01) using a router with a 30mm Guide Bush and 12.7mm Straight Flute Cutter. Using any equipment other than that specified is the responsibility of the installer.

INITIAL CUT

1. Position Worktop on top of carcasses and mark the position of the edge of the Curved Base Carcass on the worktop (A).
2. Place the Worktop Jig on the worktop so the end of the jig is 23mm beyond the edge of carcass mark (A) and 2mm forward of the rear of the worktop.
3. Firmly clamp Jig in position and make a series of passes with the router increasing the depth of cut 5mm at a time until the cut is complete.

TOP TIP

When cutting the right hand end rout the worktop from the top, and when cutting the left hand end, rout the worktop from the underside.

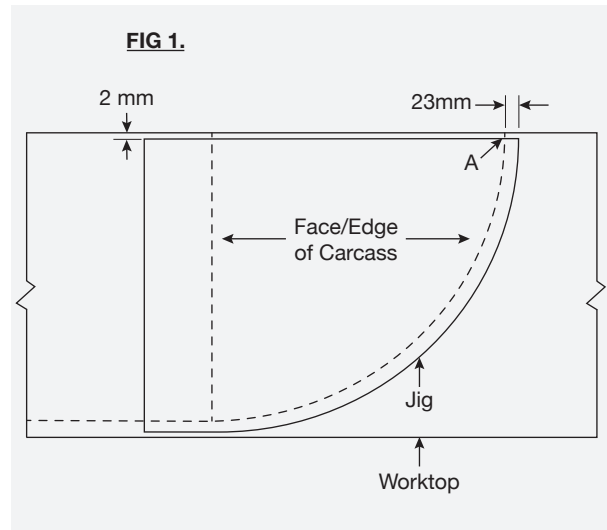

FINAL CUT TO SHAPE

1. Reposition the jig so the end of the jig is 21mm beyond the edge of carcass mark (A) and flush with the rear of the worktop.
2. Make one slow steady clean pass with the router to finish the end.

NB. The pass must NOT be so slow that the worktop overheats.

TOP TIP

To prevent burning the worktop make sure the router is kept moving at a steady pace and never stationary

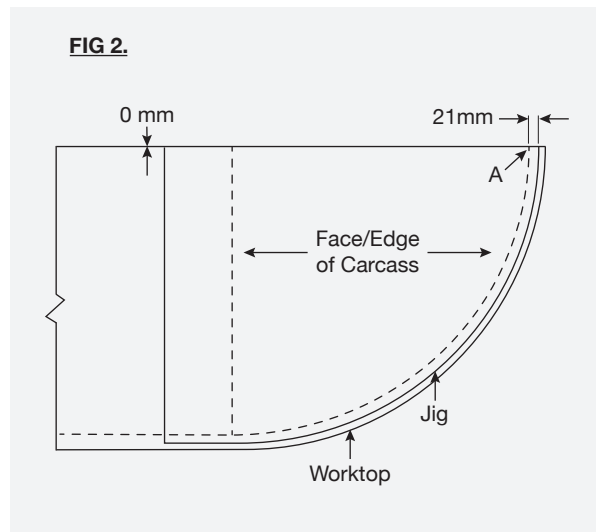

FINE FINISHING THE EDGE

1. Remove the arris from the top and bottom edges of the cut section with a file or sand paper to match the edge profile of the rest of the worktop.
2. Finally buff the cut edge with a soft cloth and a proprietary cutting compound to create the perfect finish.