

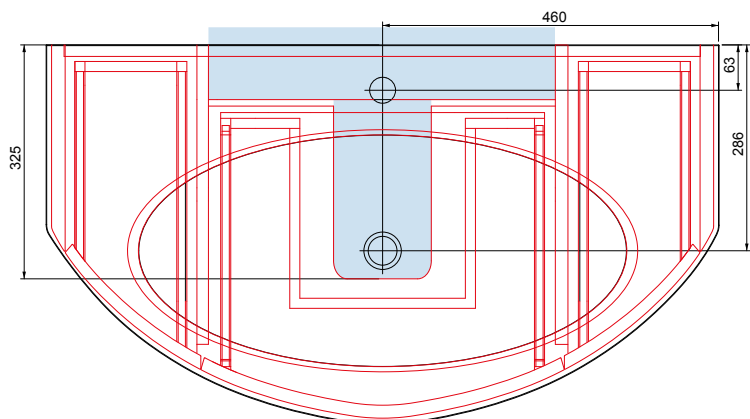

| | |
|-------------|-------------------------------|
| PRODUCT | ULTIMO 900 VANITY UNIT (47KG) |
| UNIT SIZE | 900w x 515d x 550h |
| CAST BASIN | TRESSA (12KG) |
| GLASS BASIN | LESINA (17KG) |
| BASIN SIZE | 920w x 520d x 15h |

FITTING ADVICE

- The shaded areas indicate the clear voids for the running of services
- This unit is heavy. A secure wall fixing is required
- To aid installation, it is recommended to remove the drawers to give full access and to avoid damage
- Recommended height from floor to top of vanity unit carcass is 810mm
- All wall to carcass and wall to basin joints should be sealed with silicone
- All dimensions are in mm

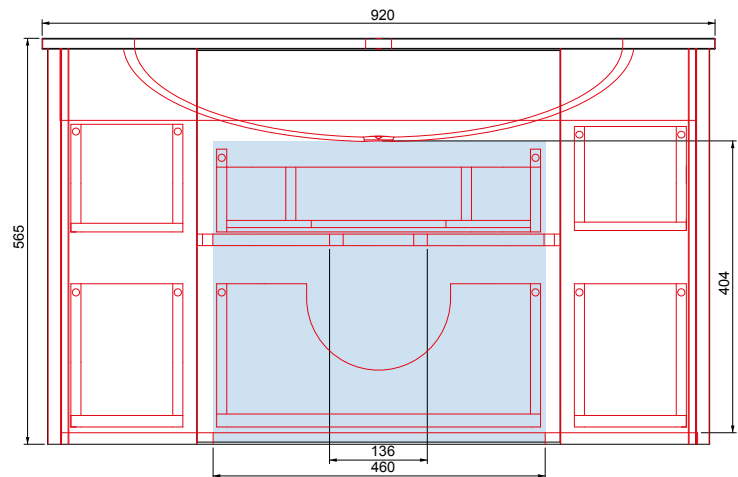
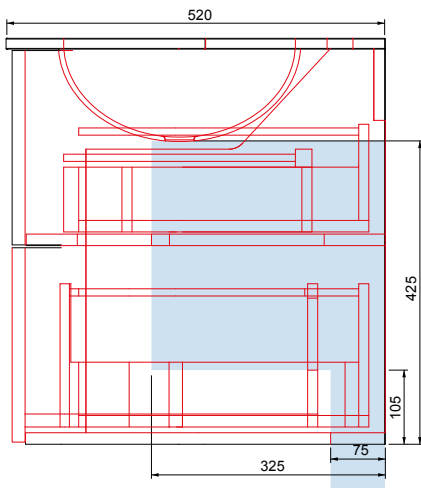

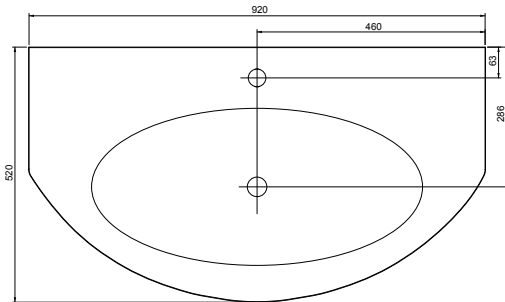
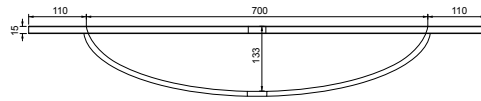
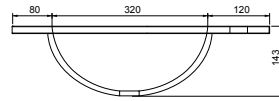

CAST MARBLE BASINS

The core ingredient of our Cast Marble basins is Dolomite Marble which is formed through volcanic action. The rock is milled and purified before being mixed with polymer resin formed into the required shape and then coated with a resin and quartz mixed gel coat to save its pigment and smooth finish.

The result is an extremely durable and easy to maintain product coupled with the benefit of constant sizing and smooth finishing that cannot be matched by traditional ceramics. Scratches are also repairable making this a more forgiving option. Cast basins have a sharp and ultra modern structured appeal to them.

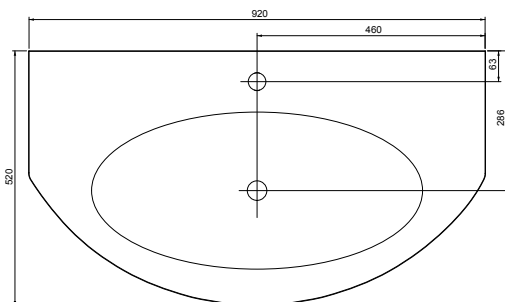
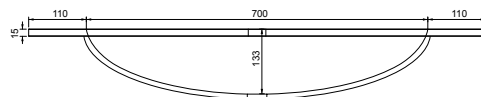
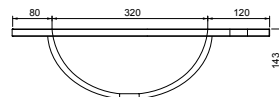

GLASS BASINS

Glass basins are perfectly formed and beautiful and benefit from being naturally anti-bacterial. They are a durable alternative to standard basins and are comparable in strength. With no overflow on these basins they have a minimal clean sleek look.

There are two points to watch which could cause fracture or breakage to glass basins; **Thermal shock** can occur when there is a sudden temperature change of more than 20°C, ambient room temperature should be maintained around 16-23°C & you must avoid pouring hot water over 48°C into a glass basin.. The **waste assembly** must be hand-tightened only.



Side adjustment ± 1 mm

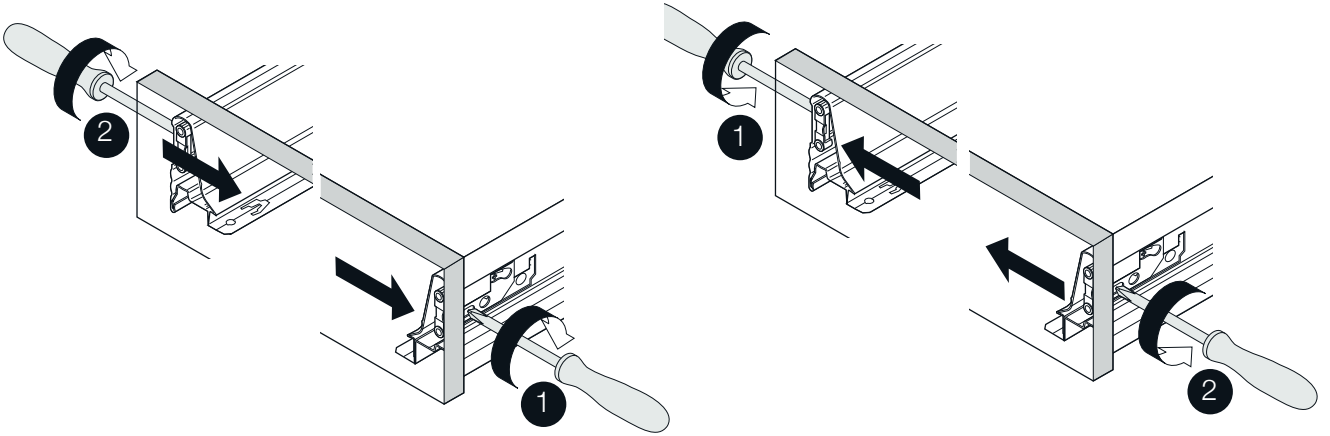

Height adjustment ± 2 mm

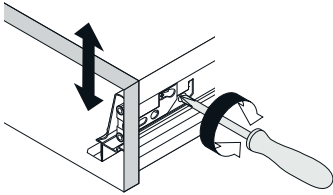

Height adjustment* ± 4 mm

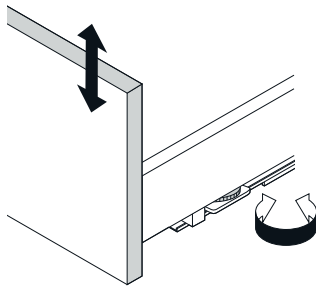

*Applicable to Ultimo 900 unit side drawers only

Push to Open Actuator adjustment

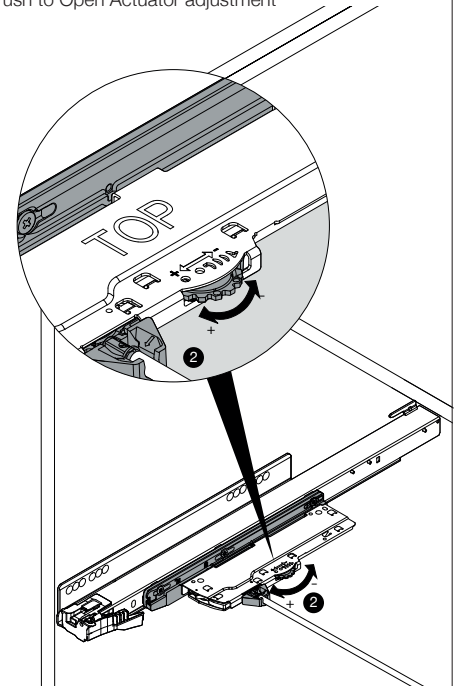

*Applicable to Solaro unit drawers only

Tilt adjustment

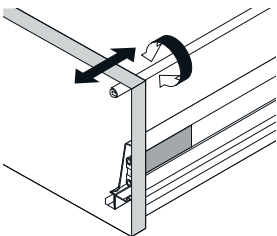

To aid installation, it is recommended to remove the drawers to give full access and to avoid damage.

1. Remove drawer boxes, to gain easier access.
2. Fix the wall bracket to the inner carcass walls.
3. Fix through this bracket into the substrate with suitable fixings
4. Once fixed in place, we recommend additional fixings are made through the rear cross rail.
5. Silicone around the top of the unit and place the basin.
6. Silicone around the unit at wall abutment.
7. Re-fit drawers.

